

⚠ WARNING

To avoid unpredictable system behavior that can cause personal injury and property damage:

- Disconnect electrical supply (when necessary) before installation, servicing, or conversion.
- Disconnect air supply and depressurize all air lines connected to this product before installation, servicing, or conversion.
- Operate within the manufacturer's specified pressure, temperature, and other conditions listed in these instructions.
- Medium must be moisture-free if ambient temperature is below freezing.
- Service according to procedures listed in these instructions.
- Installation, service, and conversion of these products must be performed by knowledgeable personnel who understand how pneumatic products are to be applied.
- After installation, servicing, or conversion, air and electrical supplies (when necessary) should be connected and the product tested for proper function and leakage. If audible leakage is present, or the product does not operate properly, do not put into use.
- Warnings and specifications on the product should not be covered by paint, etc. If masking is not possible, contact your local representative for replacement labels.

⚠ CAUTION

Polycarbonate bowls, being transparent and tough, are ideal for use with Filters and Lubricators. They are suitable for use in normal industrial environments, but should not be located in areas where they could be subjected to an impact blow, nor temperatures outside of the rated range. As with most plastics, some chemicals can cause damage. Polycarbonate bowls should not be exposed to chlorinated hydro-carbons, ketones, esters, and certain alcohols. They should not be used in air systems where compressors are lubricated with fire resistant fluids such as phosphate esters and di-esters types. In areas where polycarbonate bowls are exposed to high temperatures or atmospheres containing vapors or fluids, which are damaging to plastic, use metal bowls.

Metal bowls resist the action of most such solvents but should not be used where strong acids or bases are present or in salt laden atmospheres. Consult the factory for specific recommendations where these conditions exist.

TO CLEAN POLYCARBONATE BOWLS USE MILD SOAP AND WATER ONLY! DO NOT use cleaning agents such as acetone, benzene, carbon tetrachloride, gasoline, toluene, etc., which are damaging to this plastic.

Bowl guards are recommended for added protection of polycarbonate bowls where chemical attack may occasionally occur.

Safety Guide

For more complete information on recommended application guidelines, see the Safety Guide section of Pneumatic Division catalogs or you can download the **Pneumatic Division Safety Guide** at: www.parker.com/safety

Introduction

Follow these instructions when installing, operating, or servicing the product.

Application Limits

These products are intended for use in general purpose compressed air systems only.

	kPa	PSIG	bar
Operating Pressure Maximum	1700	250	17.0

Operating Temperature Maximum	80°C (175°F)
Operating Temperature Minimum	0°C (32°F)

ANSI Symbol

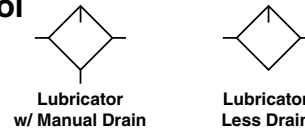

Installation

1. The lubricator should be installed with reasonable accessibility for service whenever possible. Keep pipe or tubing lengths to a minimum with inside clean and free of dirt and chips. Pipe joint compound should be used sparingly and applied only to the male pipe – never into the female port. Do not use PTFE tape to seal pipe joints – pieces have a tendency to break off and lodge inside the unit, possibly causing malfunction.
2. Install lubricator so air flows in the direction of arrow on body.
3. Installation should be upstream of the device it is to lubricate (valve, cylinders, tool, etc.).

Operation and Service

(Refer to Pictorial on Following Page)

1. Filling — The Mist lubricator can be filled without turning off the upstream pressure. Slowly remove the fill plug by turning counterclockwise. This allows the bowl pressure to vent.
 Suggested lubricant: F442
 Petroleum based oil of 100 to 200 SUS viscosity at 100°F and an aniline point greater than 200°F. (Mobil DTE24 and Sun Company Sunvis 932 are good examples). Do not use oils with adhesives, compound oils containing solvents, graphite, detergents or synthetic oils.
2. Replace the fill plug (by turning clockwise) and seat firmly. Excessive torque is not required. If leakage occurs, **DO NOT OPERATE** — conduct repairs again. The lubricator is now ready for setting.
3. Oil delivery adjustment — To adjust oil delivery, turn adjustment knob on top of the lubricator.

⚠ WARNING

FAILURE OR IMPROPER SELECTION OR IMPROPER USE OF THE PRODUCTS AND/OR SYSTEMS DESCRIBED HEREIN OR RELATED ITEMS CAN CAUSE DEATH, PERSONAL INJURY AND PROPERTY DAMAGE.

This document and other information from Parker Hannifin Corporation, its subsidiaries and authorized distributors provide product and/or system options for further investigation by users having technical expertise. It is important that you analyze all aspects of your application, including consequences of any failure and review the information concerning the product or systems in the current product catalog. Due to the variety of operating conditions and applications for these products or systems, the user, through its own analysis and testing, is solely responsible for making the final selection of the products and systems and assuring that all performance, safety and warning requirements of the application are met.

The products described herein, including without limitation, product features, specifications, designs, availability and pricing, are subject to change by Parker Hannifin Corporation and its subsidiaries at any time without notice.

EXTRA COPIES OF THESE INSTRUCTIONS ARE AVAILABLE FOR INCLUSION IN EQUIPMENT / MAINTENANCE MANUALS THAT UTILIZE THESE PRODUCTS. CONTACT YOUR LOCAL REPRESENTATIVE.

1" Lubricator Series

2L300C

Leaner — Clockwise

Richer — Counterclockwise

By counting the number of drops per minute in the sight dome, you can adjust to your requirements.

Mist lubricator — Every drop visible in the sight dome goes downstream.

Generally, one drop per minute downstream for every 10 - 15 SCFM flow is satisfactory.

25 drops per minute equals one (1) ounce per hour - volume of oil passing through the sight dome.

NOTE: This is a constant density type lubricator which delivers a constant ratio of oil air flow. Therefore, if air flow increases or decreases, oil delivery will be adjusted proportionately. **ONLY IF A DIFFERENT RATIO IS DESIRED SHOULD YOUR ADJUSTMENT KNOB SETTING BE CHANGED AFTER YOUR INITIAL SETTING.**

4. To replace fill plug, drip control, & service lubricator:
 - A. Turn off air supply and depressurize the unit.
 - B. Refer to pictorial for servicing and torque values.
 - C. Turn on air supply and check lubricator for leakage. If leakage occurs, **DO NOT OPERATE** — conduct repairs again.

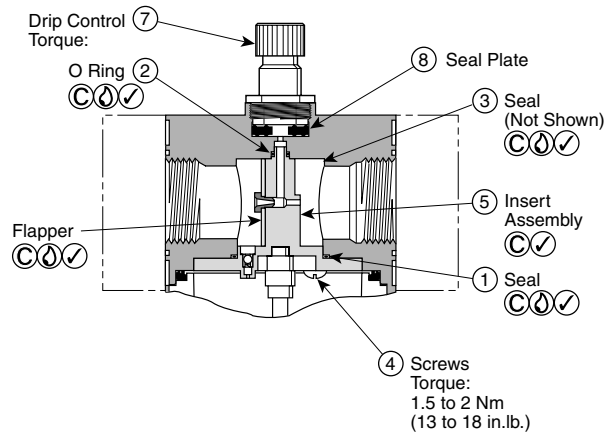
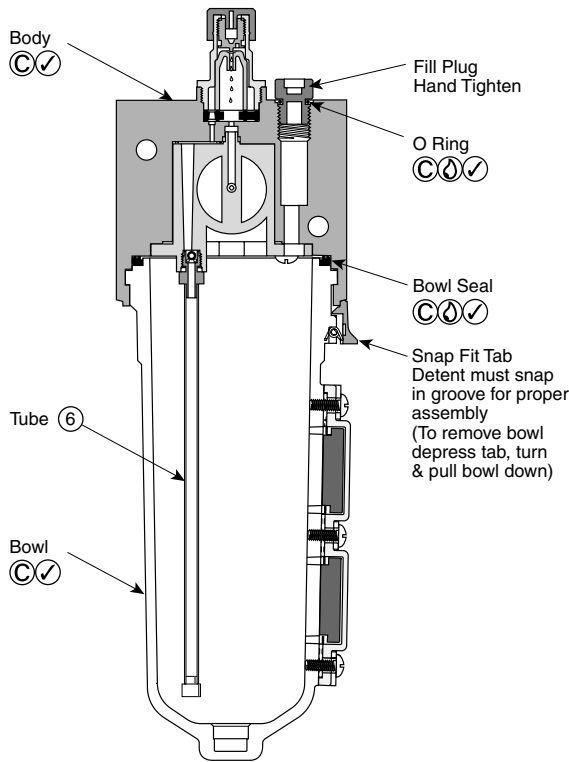

Service Kits Available

Description	Kit Number	Contains Items
Lubricator Repair Kit	P3NKA00RL	(1) Seal, (2) O-Ring, (3) Seal (Not Shown), (4) Screws, (5) Insert Assembly (Including Flapper), and (6) Tube
Sight Dome / Drip Control (Polycarbonate)	PS740	(7) Drip Control, (8) Seal Plate
Sight Dome / Drip Control (Polyamide / Nylon)	PS740N	

- (D) Lightly grease with provided lubricant.
- (✓) Inspect for nicks, scratches, and surface imperfections. If present, reduced service life is probable and future replacement should be planned.
- (C) Clean with lint-free cloth.

