

Pneumatic Division
 Richland, Michigan 49083
 269-629-5000

Installation & Service Instructions:
2F300E
1" Particulate, Adsorber & Coalescing Filter
ISSUED: October, 2006
Supersedes: March, 2005
 Doc.# 2F300, ECN# 061068, Rev. 9

⚠ WARNING

To avoid unpredictable system behavior that can cause personal injury and property damage:

- Disconnect electrical supply (when necessary) before installation, servicing, or conversion.
- Disconnect air supply and depressurize all air lines connected to this product before installation, servicing, or conversion.
- Operate within the manufacturer's specified pressure, temperature, and other conditions listed in these instructions.
- Medium must be moisture-free if ambient temperature is below freezing.
- Service according to procedures listed in these instructions.
- Installation, service, and conversion of these products must be performed by knowledgeable personnel who understand how pneumatic products are to be applied.
- After installation, servicing, or conversion, air and electrical supplies (when necessary) should be connected and the product tested for proper function and leakage. If audible leakage is present, or the product does not operate properly, do not put into use.
- Warnings and specifications on the product should not be covered by paint, etc. If masking is not possible, contact your local representative for replacement labels.

Safety Guide

For more complete information on recommended application guidelines, see the Safety Guide section of Pneumatic Division catalogs or you can download the **Pneumatic Division Safety Guide** at: www.parker.com/safety

Introduction

Follow these instructions when installing, operating, or servicing the product.

Application Limits

These products are intended for use in general purpose compressed air systems only.

Adsorber Filters are not effective on: Carbon monoxide, carbon dioxide, methane, ethane, ethylene or hydrogen. For a complete list of vapors that can and cannot be adsorbed effectively by activated charcoal adsorbers consult the factory.

Maximum Recommended Pressure Drop:

	kPa	PSIG	bar
Particulate Filter	70	10	0.7
Operating Pressure Maximum	1700	250	17.0
Operating Temperature Maximum	80°C (175°F)		
Operating Temperature Minimum	0°C (32°F)		

ANSI Symbols

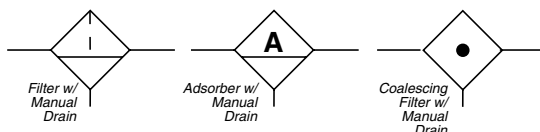

Installation

1. The filter should be installed with reasonable accessibility for service whenever possible – repair service kits are available. Keep pipe or tubing lengths to a minimum with inside clean and free of dirt and chips. Pipe joint compound should be used sparingly and applied only to the male pipe – never into the female port. Do not use PTFE tape to seal pipe joints – pieces have a tendency to break off and lodge inside the unit, possibly causing malfunction. Also, new pipe or hose should be installed between the filter and equipment being protected.
2. The upstream pipe work must be clear of accumulated dirt and liquids.
3. Select a filter location as close as possible to the equipment being protected and upstream of any pressure regulator.
4. Install filter so that air flows in the direction of arrow on body.
5. Install filter vertically with bowl drain mechanism at the bottom. Free moisture will thus drain into the sump “quiet zone” at the bottom of the bowl.

Operation and Service

1. Manual drain filters must be drained regularly before the separated moisture and oil reaches the bottom of the lower baffle.
2. The particulate filter element should be removed and replaced when pressure differential across the filter is 10 PSIG.
3. Adsorber elements are designed to adsorb vaporous contaminants. The relative efficiency of an adsorber varies depending on the vapor to be adsorbed and the environmental temperature. At higher temperatures, adsorbers become less efficient.

Adsorber elements are not particle filters. All particles and aerosols should be removed prior to adsorbing vaporous contaminants. The initial pressure drop across an adsorber element (1.5 PSIG maximum) should never increase. The presence of any liquids, aerosols or particulate matter in an adsorber indicates that the effective life of the element has been exceeded and the element should be replaced and the system cleaned.

⚠ WARNING

FAILURE OR IMPROPER SELECTION OR IMPROPER USE OF THE PRODUCTS AND/OR SYSTEMS DESCRIBED HEREIN OR RELATED ITEMS CAN CAUSE DEATH, PERSONAL INJURY AND PROPERTY DAMAGE.

This document and other information from The Company, its subsidiaries and authorized distributors provide product and/or system options for further investigation by users having technical expertise. It is important that you analyze all aspects of your application, including consequences of any failure and review the information concerning the product or systems in the current product catalog. Due to the variety of operating conditions and applications for these products or systems, the user, through its own analysis and testing, is solely responsible for making the final selection of the products and systems and assuring that all performance, safety and warning requirements of the application are met.

The products described herein, including without limitation, product features, specifications, designs, availability and pricing, are subject to change by The Company and its subsidiaries at any time without notice.

EXTRA COPIES OF THESE INSTRUCTIONS ARE AVAILABLE FOR INCLUSION IN EQUIPMENT / MAINTENANCE MANUALS THAT UTILIZE THESE PRODUCTS. CONTACT YOUR LOCAL REPRESENTATIVE.

The most effective method of testing whether an element needs to be replaced is to smell the air coming from the adsorber. Offensive odors will be present well before oil levels become detectable.

4. For Coalescing filter, a 5 micrometer pre-filter is recommended to protect the high efficiency filter and to prolong the elements life.
5. The differential pressure indicator, located on top of the filter body, gives a visual indication of the pressure differential across the filter element. Change the filter element when half or more of the orange piston is above the retaining ring when air is flowing. For units without a differential pressure indicator, pressure differential gauges should be used to determine when the maximum recommended pressure differential has been reached.
6. Shut off air supply and depressurize the unit, before servicing.
7. After servicing, apply system pressure and check for air leaks. If leakage occurs, Do Not Operate — conduct servicing again.

Service Kits Available

Description	Kit Number	Contains Items
Element Kits -		
5 Micron	P3NKA00ESE	(5) Bowl Seal and (2) Element
40 Micron	P3NKA00ESG	
Adsorber	P3NKA00ESA	
25 Micron Porous Bronze	P3NKA00ESJ	
Coalescing / Element Grade 6	P3NKA00ESC	
Coalescing / Element Grade 10	P3NKA00ES9	
DPI Repair Kit	PS781	(6) DPI components (not all shown)
Auto Drain Kit	PS506	(7) Auto Drain Assembly

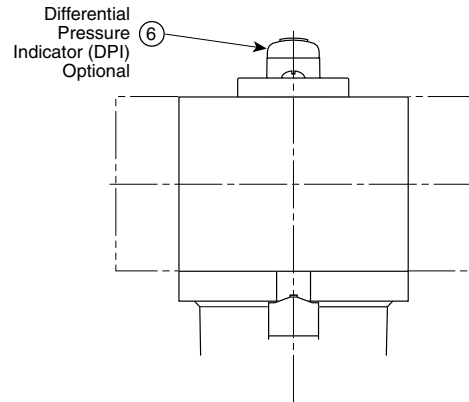
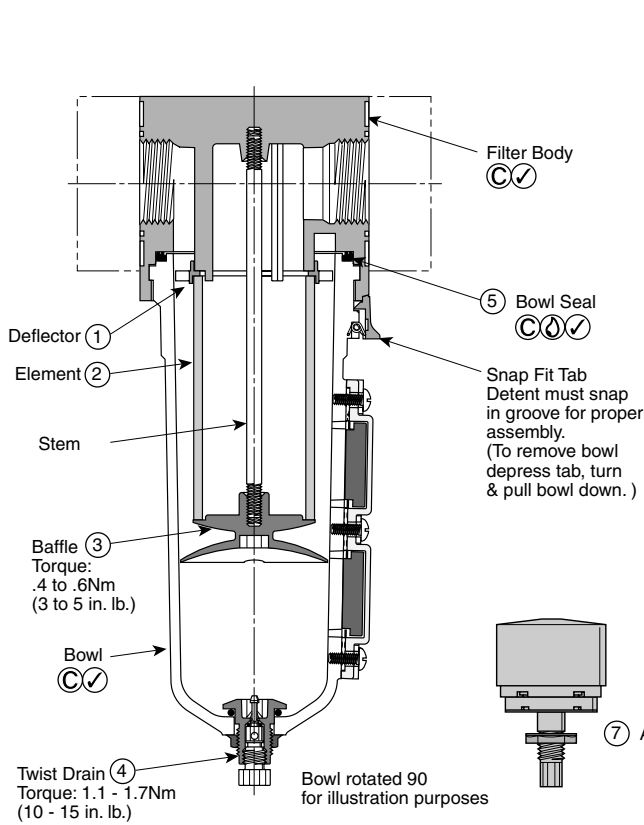

Coalescing Unit Shown

- ① Lightly grease with provided lubricant.
- ✓ Inspect for nicks, scratches, and surface imperfections. If present, reduced service life is probable and future replacement should be planned.
- Ⓒ Clean with lint-free cloth.

